

## Safety relays - PSR-MC73-5NO-1DO-24DC-SP - 1015526

Please be informed that the data shown in this PDF Document is generated from our Online Catalog. Please find the complete data in the user's documentation. Our General Terms of Use for Downloads are valid (<http://phoenixcontact.com/download>)



Safety relay for emergency stop, safety doors, light grid up to SILCL 3, Cat. 4, PL e, 1- or 2-channel operation, cross-circuit detection, can be retriggered, fall back/on delay 0.2 s to 300 s, 5 enabling current paths,  $U_S = 24 \text{ V DC}$ , pluggable Push-in terminal block

### Your advantages

- ✓ Up to Cat.4/PL e according to ISO 13849-1, SILCL 3 according to IEC 62061
- ✓ Low housing width of only 22.5mm
- ✓ Single and two-channel control
- ✓ 5 enabling current paths, 1 digital signal output
- ✓ Manually monitored and automatic activation in a single device



### Key Commercial Data

Packing unit	1 pc
GTIN	 4 055626 496566
GTIN	4055626496566
Custom tariff number	85371098
Country of origin	Germany

### Technical data

#### Note

Utilization restriction	EMC: class A product, see manufacturer's declaration in the download area
-------------------------	---------------------------------------------------------------------------

#### Dimensions

Width	22.5 mm
Height	117.5 mm

# Safety relays - PSR-MC73-5NO-1DO-24DC-SP - 1015526

## Technical data

### Dimensions

Depth	114.5 mm
-------	----------

### Ambient conditions

Ambient temperature (operation)	-35 °C ... 60 °C (observe derating)
Ambient temperature (storage/transport)	-40 °C ... 85 °C
Max. permissible relative humidity (operation)	75 % (on average, 85% infrequently, non-condensing)
Max. permissible humidity (storage/transport)	75 % (on average, 85% infrequently, non-condensing)
Maximum altitude	≤ 2000 m (Above sea level)

### Power supply

Designation	A1/A2
Rated control circuit supply voltage $U_s$	24 V DC -20 % / +25 %
	19.2 V DC ... 30 V DC
Rated control supply current $I_s$	typ. 80 mA
Power consumption at $U_s$	typ. 1.92 W
Inrush current	typ. 28 A ( $\Delta t = 30 \mu s$ at $U_s$ )
Filter time	10 ms (For the logic. At A1 in the event of voltage dips at $U_s$ )
Protective circuit	Serial protection against polarity reversal Suppressor diode

### Digital inputs

Input name	Sensor circuit
	S12, S22
Description of the input	safety-related sensor inputs
Number of inputs	2
Input voltage range "0" signal	0 V DC ... 5 V DC
Input voltage range "1" signal	11 V DC ... 30 V DC
Input current range "0" signal	0 mA ... 2 mA
Inrush current	< 11 mA (typically with $U_s$ )
Current consumption	< 4.5 mA (typically with $U_s$ )
Filter time	max. 3 ms (Test pulse width of low test pulses)
	min. 21 ms (Test pulse rate for low test pulse)
Max. permissible overall conductor resistance	150 $\Omega$
Concurrence	$\infty$
Limit frequency	min. 0 Hz
	max. 1 Hz
Protective circuit/component	Varistor

### 2. Digital inputs

Input name	Start circuit
------------	---------------

# Safety relays - PSR-MC73-5NO-1DO-24DC-SP - 1015526

## Technical data

### 2. Digital inputs

	S34
Description of the input	non-safety-related
Number of inputs	1
Input voltage range "0" signal	0 V DC ... 5 V DC
Input voltage range "1" signal	11 V DC ... 30 V DC
Input current range "0" signal	0 mA ... 2 mA
Inrush current	< 8.6 mA (typically with U <sub>S</sub> )
Current consumption	< 3.2 mA (typically with U <sub>S</sub> )
Filter time	max. 3 ms (Test pulse width of low test pulses)
	min. 21 ms (Test pulse rate for low test pulse)
Max. permissible overall conductor resistance	150 Ω
Limit frequency	min. 0 Hz
	max. 1 Hz
Protective circuit/component	Varistor

### Relay outputs: enabling current path

Output name	Enabling current paths
	13/14, 23/24/34, 47/48/58
Output description	2 N/O contacts each in series, safety-related, floating
Number of outputs	3 (undelayed: 13/14, 23/24/34)
	2 (delayed: 47/48/58)
Contact type	5 enabling current paths
Contact material	AgSnO <sub>2</sub>
Switching voltage	min. 12 V AC/DC
	max. 250 V AC (Observe the load curve)
Limiting continuous current	6 A
Inrush current	min. 3 mA
	max. 6 A
Sq. Total current	108 A <sup>2</sup> (observe derating)
Switching capacity	min. 60 mW
Switching frequency	0.5 Hz (depending on the set delay time)
Mechanical service life	10x 10 <sup>6</sup> cycles
Switching capacity according to IEC 60947-5-1	4 A (24 V (DC13))
	5 A (250 V (AC15))
Output fuse	6 A gL/gG
	4 A gL/gG (for low-demand applications)

### Alarm outputs

## Safety relays - PSR-MC73-5NO-1DO-24DC-SP - 1015526

### Technical data

#### Alarm outputs

Designation	M1
Output description	PNP
	non-safety-related
Number of outputs	1
Voltage	approx. 23 V DC ( $U_s - 1$ V)
Current	max. 100 mA
Maximum inrush current	500 mA ( $\Delta t = 10$ ms at $U_s$ )
Protective circuit/component	Suppressor diode
Short-circuit protection	Yes

#### Clock outputs

Designation	S11, S21
Output description	PNP
	non-safety-related
Number of outputs	2
Voltage	corresponds to $U_s$
Current	max. 100 mA
Maximum inrush current	500 mA ( $\Delta t = 10$ ms at $U_s$ )
Cable length	max. 150 m
Protective circuit/component	Suppressor diode
Short-circuit protection	Yes

#### Times

Typical pickup time at $U_s$	500 ms (with $U_s$ when controlled via A1)
Typical response time at $U_s$	< 40 ms (automatic start)
	< 30 ms (manual, monitored start)
Typical release time at $U_s$	< 25 ms (when controlled via S12 and S22 (only for undelayed contacts))
	< 5 ms (when controlled via A1; applicative deactivation via A1/A2 is not permitted)
Delay time range	0.2 s ... 300 s $\pm 5$ % (can be set for 47/48/58)
Restart time	< 1 s (Boot time)
Recovery time	500 ms (following demand of the safety function)

#### General

Relay type	Electromechanical relay with force-guided contacts in accordance with IEC/EN 61810-3
Nominal operating mode	100% operating factor
Net weight	155.43 g
Mounting position	vertical or horizontal

# Safety relays - PSR-MC73-5NO-1DO-24DC-SP - 1015526

## Technical data

### General

Mounting type	DIN rail mounting
Assembly instructions	See derating curve
Degree of protection	IP20
Min. degree of protection of inst. location	IP54
Housing material	PBT
Housing color	yellow
Status display	5 x bi-color LED

### Connection data

Connection method	Push-in connection
pluggable	Yes
Conductor cross section solid	0.2 mm <sup>2</sup> ... 1.5 mm <sup>2</sup>
Conductor cross section flexible	0.2 mm <sup>2</sup> ... 1.5 mm <sup>2</sup>
Conductor cross-section AWG	24 ... 16
Conductor cross-section flexible with ferrule without plastic sleeve	0.25 mm <sup>2</sup> ... 1.5 mm <sup>2</sup> (only together with CRIMPFOX 6)
Conductor cross-section flexible with ferrule and plastic sleeve	0.25 mm <sup>2</sup> ... 1.5 mm <sup>2</sup> (only together with CRIMPFOX 6)
Stripping length	8 mm

### Safety-related characteristic data

Stop category in accordance with IEC 60204	0
	1
Designation	IEC 61508 - High demand
Safety Integrity Level (SIL)	3
Designation	IEC 61508 - Low demand
Safety Integrity Level (SIL)	3
Designation	EN ISO 13849
Performance level (PL)	e (4 A DC13; 5 A AC15; 8760 switching cycles/year)
Category	4
Designation	EN 62061
Safety Integrity Level Claim Limit (SIL CL)	3

### Standards and Regulations

Designation	Air clearances and creepage distances between the power circuits
Standards/regulations	DIN EN 50178
Rated insulation voltage	250 V AC
Rated surge voltage/insulation	Basic insulation 4 kV between all current paths and housing
	Safe isolation, reinforced insulation 6 kV between (A1, A2, S11, S12, S21, S22, S34, M1) and enabling current path (13/14) and enabling current path (23/24/34) and enabling current path (47/48/58)
Degree of pollution	2

# Safety relays - PSR-MC73-5NO-1DO-24DC-SP - 1015526

## Technical data

### Standards and Regulations

Overvoltage category	III
Shock	10g (operation), 15g (transport)
Vibration (operation)	10 Hz ... 150 Hz, 2g
Conformance	CE-compliant

### Environmental Product Compliance

REACH SVHC	Lead 7439-92-1
China RoHS	Environmentally Friendly Use Period = 50 years
	For details about hazardous substances go to tab "Downloads", Category "Manufacturer's declaration"

## Drawings

Block diagram

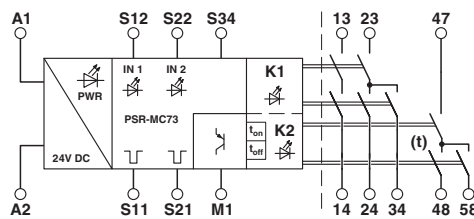

# Safety relays - PSR-MC73-5NO-1DO-24DC-SP - 1015526

Circuit diagram

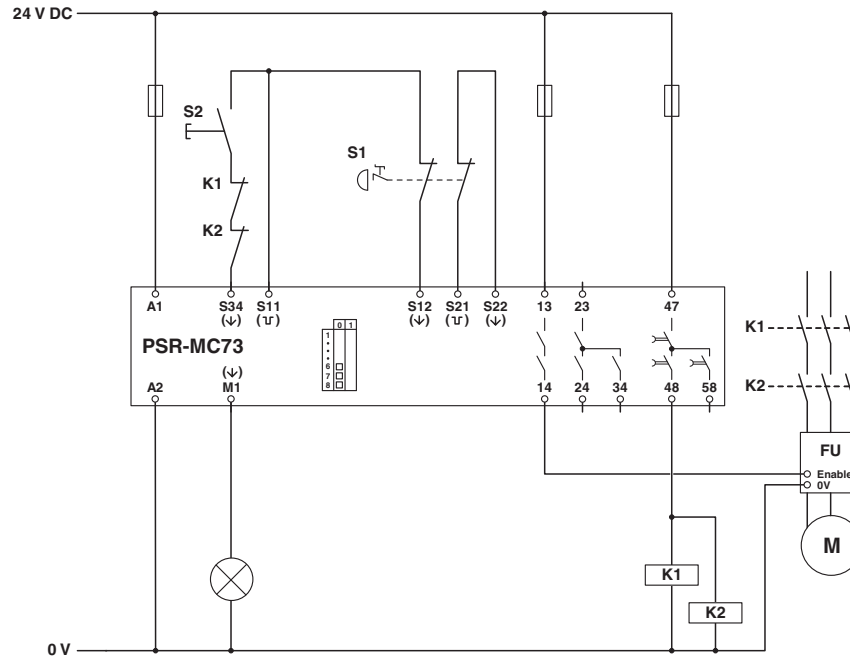

## Classifications

eCl@ss

eCl@ss 10.0.1	27371819
eCl@ss 11.0	27371819
eCl@ss 9.0	27371819

ETIM

ETIM 6.0	EC001449
ETIM 7.0	EC001449

## Approvals

Approvals

Approvals

UL Listed / cUL Listed / cULus Listed

Ex Approvals

## Safety relays - PSR-MC73-5NO-1DO-24DC-SP - 1015526

### Approvals

#### Approval details

UL Listed		<a href="http://database.ul.com/cgi-bin/XYV/template/LISEXT/1FRAME/index.htm">http://database.ul.com/cgi-bin/XYV/template/LISEXT/1FRAME/index.htm</a>	FILE E 140324
-----------	--	-------------------------------------------------------------------------------------------------------------------------------------------------------	---------------

cUL Listed		<a href="http://database.ul.com/cgi-bin/XYV/template/LISEXT/1FRAME/index.htm">http://database.ul.com/cgi-bin/XYV/template/LISEXT/1FRAME/index.htm</a>	FILE E 140324
------------	--	-------------------------------------------------------------------------------------------------------------------------------------------------------	---------------

cULus Listed			
--------------	--	--	--

### Accessories

#### Accessories

#### Coding element

Coding profile - CP-MSTB - 1734634

Coding profile, is inserted into the slot on the plug or inverted header, red insulating material



Coding section - CR-MSTB - 1734401

Coding section, inserted into the recess in the header or the inverted plug, red insulating material

